



INSTALLATION AND TESTING PROCEDURE



North Shore Safety
7335 Production Drive
Mentor, Ohio 44060
Phone: 440.205.9188
Fax: 440.205.9187
Toll-free: 877.472.3348
Web: www.nssltd.com
Email: sales@nssltd.com

IMPORTANT!

THIS DEVICE MUST BE INSTALLED BY A QUALIFIED PERSON WHO UNDERSTANDS ELECTRICAL CIRCUITS.

Please read all the information on this sheet.

WARNING

A Ground Fault Circuit Interrupter (GFCI) is an electrical safety device that under normal use is intended to mitigate electric shock hazard. Use this product only within the specified operating parameters. (Failure to do so may result in bodily injury.) Consult a licensed electrician for assistance on installation and repairs. Do not use this GFCI if it fails to function as instructed. Never attempt to tamper with this device. This GFCI must never be used as a switch to connect or disconnect power. (Power should be disconnected at main power feed or by secondary switch located at the primary feed of GFCI.) This GFCI is not an over-current protection device. (An appropriate fuse or circuit breaker must be used in series at primary power feed.) This GFCI does not provide protection against shocks caused by holding both circuit conductors. This GFCI does not provide protection against electrical shocks generated by the conductors supplying power to the device. Note: primary feed to GFCI is live even when GFCI is tripped. (Power should be disconnected at main service panel before servicing load side of GFCI.)

- Do not use this device to feed power to life support apparatus.
- To minimize nuisance tripping:
 - Do not use on swimming pool equipment installed before 1965 NEC code.
 - Do not use on electric clothes dryers or electric ranges with frames grounded by neutral conductor.
- Installation must comply with local and national electrical codes (NEC).
- During installation, turn power off at the service panel to prevent serious injuries.

What is a GFCI?

A GFCI is a device designed to interrupt power when a ground fault (a current that takes a path to ground) exceeds a predetermined value. This power interruption is quickly accomplished to prevent serious injuries.

Why do we need a GFCI?

The human body is conductive to electricity, and electric shocks can be fatal. Any electrical tool or appliance is a potential shock hazard, especially when used near wet locations; and this is where a GFCI is needed the most. This is why most electrical codes require GFCI protection in kitchens, bathrooms, garages, outdoor outlets, laundry rooms, workshops, etc. North Shore Safety's GFCI, LineGard®, will offer such protection. Its safety scope surpasses its peers to include open supply protection (most receptacle type GFCIs do not sense open neutral condition) as well as dual indication of operating modes, with fault indication or power status.

How does a GFCI operate?

The GFCI constantly monitors the current-balance of the conductors supplying power to the load. When a ground fault occurs - by a leakage or by shock - the imbalance of current is sensed and the GFCI trips when the ground fault exceeds 5 mA +/- 1 mA. The tripping action must be within a fraction of a second to prevent serious injuries.

What a GFCI cannot do:

- Will not protect the circuit's line side.
- Will not protect you when touching two current carrying conductors of opposite polarity (the GFCI sees this as a load).
- Will not protect you when touching a line of another circuit.
- Will not detect overcurrent.

North Shore Safety TWO YEAR LIMITED MANUFACTURER'S WARRANTY

North Shore Safety warrants to the consumer its Line-Gard Ground Fault Circuit Interrupter (GFCI) to be free from defects in materials and workmanship, under normal use and service, for a period of two years from date of purchase. North Shore Safety, at its option, will repair or replace the defective GFCI without charge within 2-years of the date of the product's purchase provided that the defect occurred during normal use. The defective unit must be returned freight prepaid, with a RGA (Returned Goods Authorization) including a description of the problem, and a proof of purchase date to the Quality Assurance Dept. North Shore Safety, Ltd. 7335 Production Drive, Mentor, OH 44060.

North Shore Safety will not be liable, directly or indirectly, for installation or removal of this device, or for any personal injury, or property damages, or incidental, indirect, or consequential damages of any kind, as a result of a defective device. The exclusive remedy, under this warranty, is the repair or replacement of the defective device. In no case shall North Shore Safety's liability exceed the purchase price. This warranty is void or not covered if this device is found to be: not properly installed, tampered with, not used according to label instructions and ratings, enclosure breached (button cover label, conduit hubs, vent, or lid fasteners), surged, short circuited, or abused.

INSTALLATION PROCEDURE:

DANGER: HAZARD OF ELECTRICAL SHOCK, BURN, OR EXPLOSION. Disconnect power at main panel before you start the installation. Failure to do so will cause severe shock, personal injury or death.

IMPORTANT:

1. Read all the instructions in this leaflet and on the device label.
2. Identify all the features and wires (see drawings below or on next page).
3. Identify Line wires (solid color) and Load wires (with stripes).
4. Verify that the ratings on the device match your field line ratings.
5. Disconnect power at main panel.
6. Determine GFCI location and drill mounting holes using template provided.
7. Strip wires to 5/8".
8. Feed wires into junction box through appropriate hole and secure cable or conduit end of GFCI to junction box.
9. Choose the right wiring application and connect wires according to the drawings and instructions below or on the next page.
10. Secure GFCI box to mounting panel.
11. **NOTE: ALL WIRE CONNECTIONS SHOULD BE MADE WITH APPROPRIATE RATED WIRE CONNECTORS.**

Permanent 30A Single and Split Phase Series

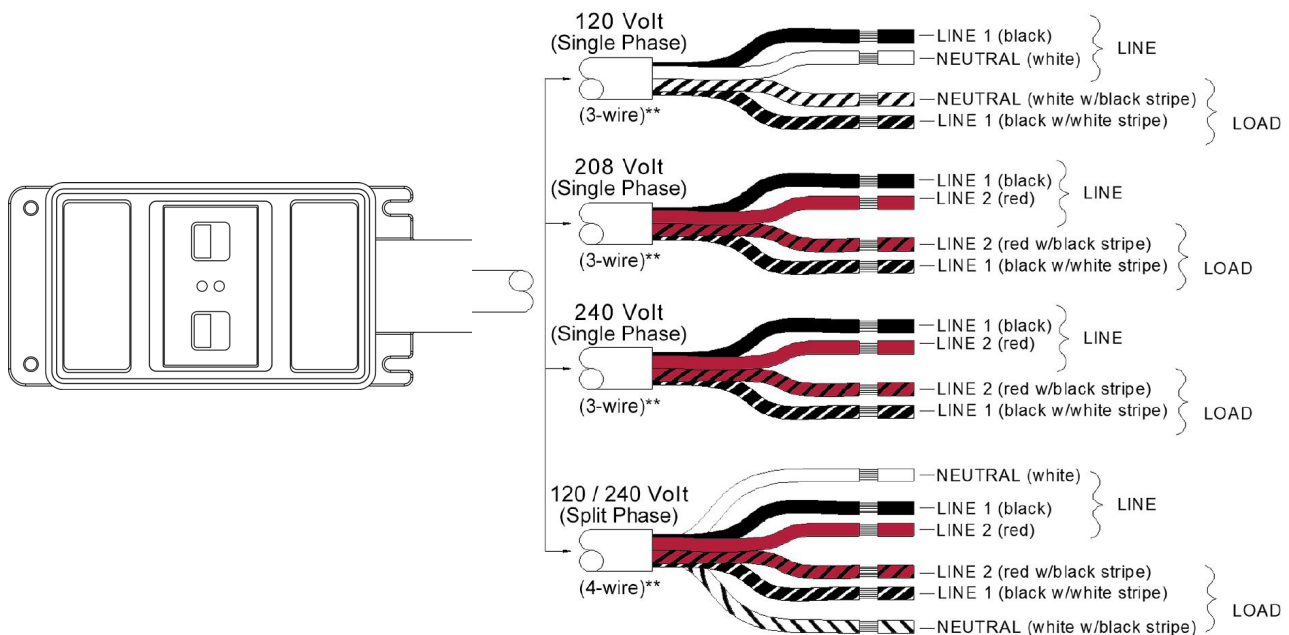

**** Ground wire is connected externally.** Ground wire does not enter or exit the GFCI box. Although GFCI does not require Ground to operate, Ground connection is recommended and should be made at junction box.

2-Pole 3-Wire, 120VAC (single phase) application:

- Connect Field-Line 1 wire to GFCI Line-Line1 wire (Solid Black) using a wire connector.
- Connect Field-Neutral wire to GFCI Line-Neutral wire (Solid White) using a wire connector.
- Connect GFCI Load-Line1 wire (Black W/White Stripe) to protected equipment or receptacle Line 1.
- Connect GFCI Load-Neutral wire (White W/Black Stripe) to protected equipment or receptacle Neutral.

2-Pole 3-Wire, 208VAC or 240VAC (single phase) application:

- Connect Field-Line 1 wire to GFCI Line-Line1 wire (Solid Black) using a wire connector.
- Connect Field-Line2 wire to GFCI Line-Line2 wire (Solid Red) using a wire connector.
- Connect GFCI Load-Line1 wire (Black W/White Stripe) to protected equipment or receptacle Line 1.
- Connect GFCI Load-Line2 wire (Red W/Black Stripe) to protected equipment or receptacle Line 2.

3-Pole 4-Wire, 120/240VAC (split phase) application:

- Connect Field-Line 1 wire to GFCI Line-Line1 wire (Solid Black) using a wire connector.
- Connect Field-Line2 wire to GFCI Line-Line2 wire (Solid Red) using a wire connector.
- Connect Field-Neutral wire to GFCI Line-Neutral wire (Solid White) using a wire connector.
- Connect GFCI Load-Line1 wire (Black W/White Stripe) to protected equipment or receptacle Line 1.
- Connect GFCI Load-Line2 wire (Red W/Black Stripe) to protected equipment or receptacle Line 2.
- Connect GFCI Load-Neutral wire (White W/Black Stripe) to protected equipment or receptacle Neutral.

EXTRA WIRES FOR MODELS WITH TRIP INDICATOR OPTIONS

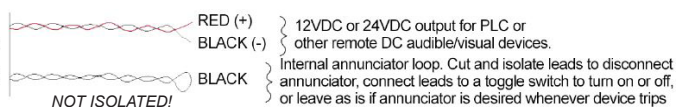
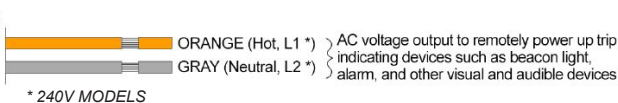

Permanent 30A Three Phase Series

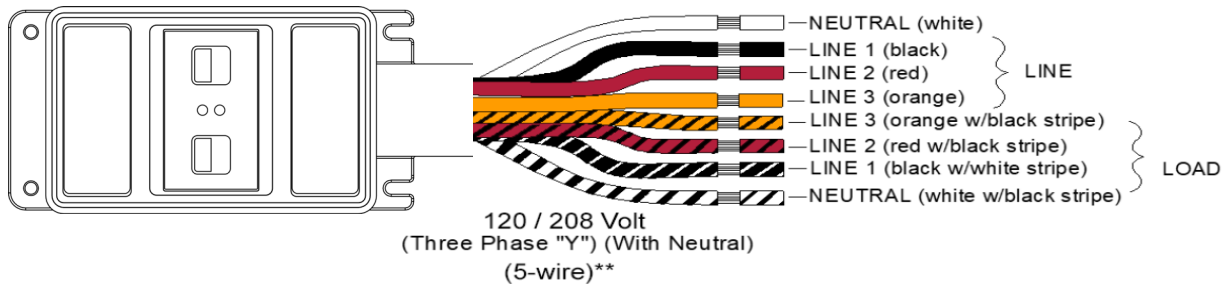
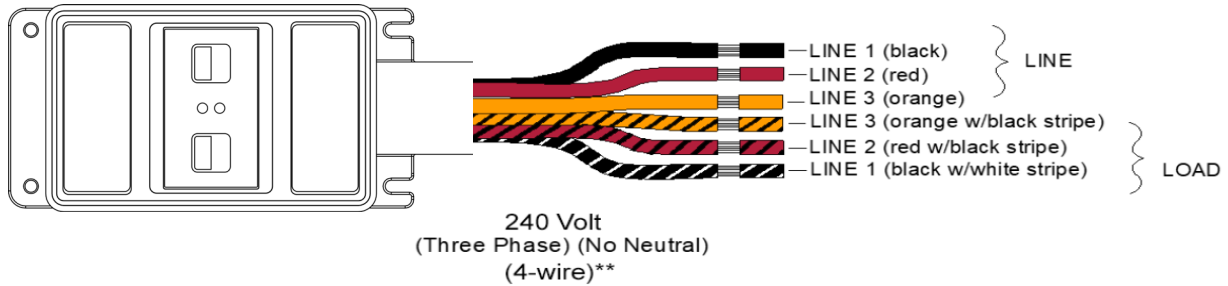
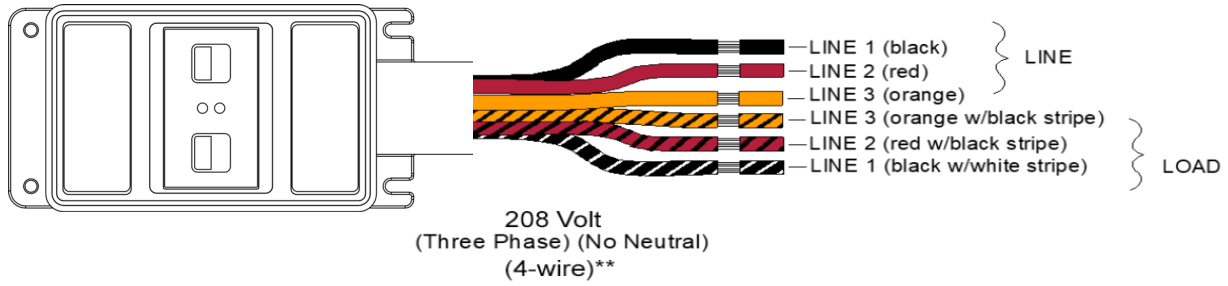

**** Ground wire is connected externally. Ground wire does not enter or exit the GFCI box. Although GFCI does not require Ground to operate, Ground connection is recommended and should be made at junction box.**

3-Pole 4-Wire, 208VAC or 240VAC (no neutral 3 phase) application:

- Connect Field-Line 1 wire to GFCI Line-Line1 wire (Solid Black) using a wire connector.
- Connect Field-Line2 wire to GFCI Line-Line2 wire (Solid Red) using a wire connector.
- Connect Field-Line3 wire to GFCI Line-Line3 wire (Solid Orange) using a wire connector.
- Connect GFCI Load-Line1 wire (Black W/White Stripe) to protected equipment or receptacle Line 1.
- Connect GFCI Load-Line2 wire (Red W/Black Stripe) to protected equipment or receptacle Line 2.
- Connect GFCI Load-Line3 wire (Orange W/Black Stripe) to protected equipment or receptacle Line 3.

4-Pole 5-Wire, 120/208VAC (with neutral 3 phase) application:

- Connect Field-Line 1 wire to GFCI Line-Line1 wire (Solid Black) using a wire connector.
- Connect Field-Line2 wire to GFCI Line-Line2 wire (Solid Red) using a wire connector.
- Connect Field-Line3 wire to GFCI Line-Line3 wire (Solid Orange) using a wire connector.
- Connect Field-Neutral wire to GFCI Line-Neutral wire (Solid White) using a wire connector.
- Connect GFCI Load-Line1 wire (Black W/White Stripe) to protected equipment or receptacle Line 1.
- Connect GFCI Load-Line2 wire (Red W/Black Stripe) to protected equipment or receptacle Line 2.
- Connect GFCI Load-Line3 wire (Orange W/Black Stripe) to protected equipment or receptacle Line 3.
- Connect GFCI Load-Neutral wire (White W/Black Stripe) to protected equipment or receptacle Neutral.
- Connect GFCI Load-Line2 wire (Red W/Black Stripe) to protected equipment or receptacle Line 2.
- Connect GFCI Load-Neutral wire (White W/Black Stripe) to protected equipment or receptacle Neutral.

Testing Procedure

TEST PROCEDURE:

Restore the power to the GFCI.

Press and release RESET button, Green Light (Power) should turn ON.

(For Auto Power-Up model, Green Light will automatically turn on when power is initiated or restored.)

Press Test button, Green Light (Power) turns off and Red Blinking Light (Fault) turns on.

CHECKING FOR CORRECT WIRING:

If GFCI is wired to protect a receptacle, plug a lamp into the protected receptacle. Press and release the RESET button, lamp should turn on. Press the TEST button. Lamp should turn off. If lamp stays on when pressing the TEST button, or if lamp does not light when pressing RESET button, turn main power off, check and correct your wiring connections. Repeat steps 1-4. If problem persists, DO NOT USE THIS GFCI. Consult a qualified electrician for assistance or replacement.

If GFCI is wired to protect equipment, press and release RESET button. Verify that the equipment power is on. Press TEST button. Equipment power should turn off. If equipment power does not come on when pressing and releasing RESET button, or if power stays on when pressing TEST button, turn main power off, check and correct your wiring connections. Repeat steps 1-4. If problem persists, DO NOT USE THIS GFCI. Consult a qualified electrician for assistance or replacement.

Always consult qualified electricians.

Technical Support:

+1(440) 205-9188

support@nssltd.com

Specifications

TECHNICAL:

Rated Voltage:	120VAC 1Ø, 208VAC 1Ø, 240VAC 1Ø, 277 VAC 1Ø (Not Listed), 240VAC 3Ø, 208VAC 3Ø, 120/208VAC 3Ø, 120/240VAC Split Ø
Operating Voltage Range:	85% to 110% of rated
Current:	Up to 30 Amps or Wiring Device Rating
Frequency:	60 Hz, (50Hz available non-U.L.)
Trip Level:	5 +/- 1mA
Phase:	Single, Split Phase, and Three-Phase
Response Time:	25 mS max @500 Ohm Fault.
Dielectric Withstand:	1500 VRMS across contact 4000 VRMS between conductors and enclosure
Surge Withstand:	Up to twenty 4kV/2kA impulses, per IEC 61000-4-5
Operating Temperature range:	-35°C to +66°C
Leakage Current @ 93% Humidity:	Zero
Overload Current:	180 Amps, 50% Inductive (25 cycles)
Let go Line Voltage:	60% of Rated
Grounded Neutral Detection:	2 Ohms or less (on applicable models only)

GENERAL:

Construction:	Industrial Grade Design
Type:	Class A
Power-Up Type *:	Auto or Manual
Endurance:	3000 Operations Minimum at Rated Load
Open Neutral Protection:	Trip Upon Loss of Neutral (on applicable models only)
Grounded Neutral Protection:	Trips if Ground and Neutral touch at load side (on applicable models only)
Power ON Indication:	Lighted Green LED
Power FAULT Indication:	Blinking Red LED, plus Optional Annunciator or AC/DC Outputs (on applicable models only)
Enclosure:	NEMA 4X
Mounting Type:	Panel, Surface and Portable
Wiring Application:	3,4,5 Wire Single, Split, and 3-Phase
Wiring Connections:	Permanent (fixed mount) (see wiring instructions)
Switch Interface:	Double Insulated
Latching Mechanism:	Electromagnetic
False trip due to impact:	None
Agency Approval:	U.L., cU.L., and cCSAus (U.L.943 and CSAC22.2 No. 144) (277VAC non-U.L.)

IMPORTANT NOTE:

*Manual configuration should be specified when automatic power-up would create an unsafe condition after restoration of circuit power.

Permanent 30A Single and Split Phase

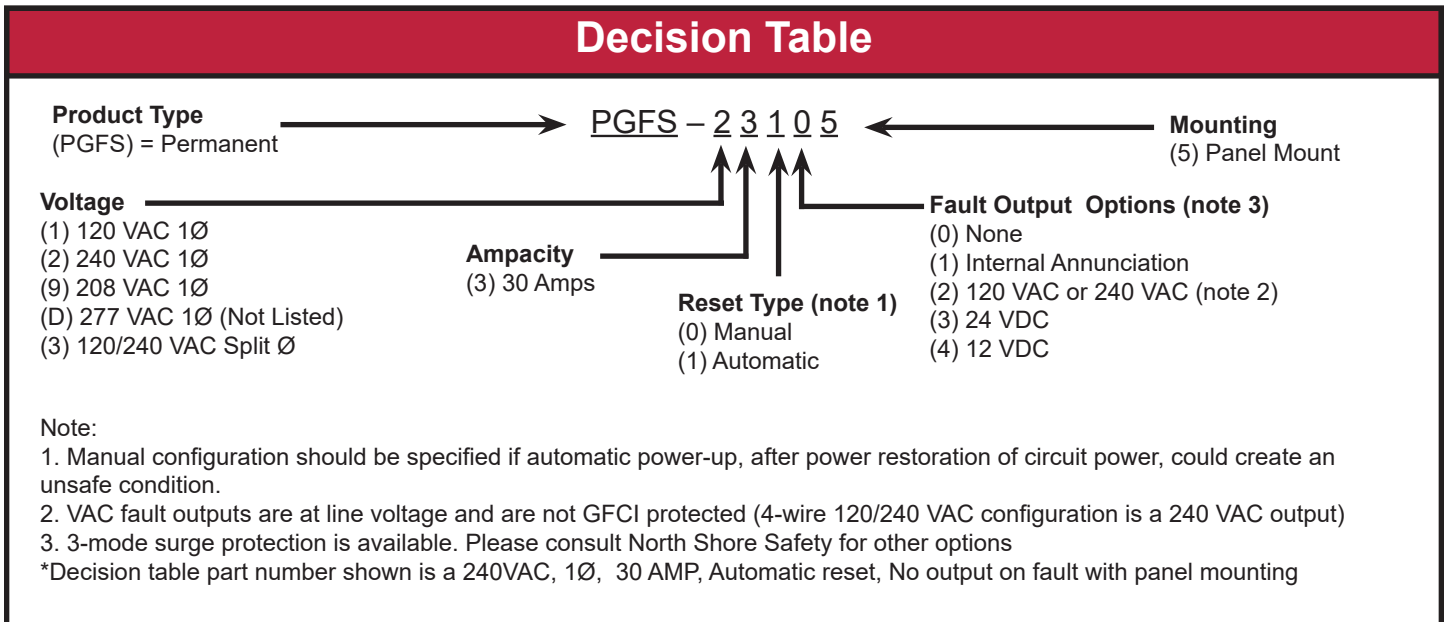

Permanent 30A Three Phase

